



SWORTEC

Treatment with MotionMaker™



Swiss High-Tech device for a better life



SWORTEC

MOTIONMAKER™

MotionMaker™ is the first rehabilitation device combining robotic mobilisation and Functional Electrical Stimulation (FES).

Muscle activity and task repetition are known to be essential in the process of recovery of voluntary mobility. FES mimics muscle action and generates inputs of natural movements much better than passive exercise and the two motorized hip-knee-ankle orthoses ensure perfectly guided and controlled movements.



The position and torque sensors, integrated into the orthoses allow to adapt the electrical stimulation and the action of the motors continuously so as to produce exactly the **pre-programmed movement and the required muscle force**.

The patented **Closed Loop Electrical Muscle Stimulation (CLEMS™)** technology adjusts the FES in real time to the needs of the movement to be trained to reproduce the kinematics and the dynamics of natural motor action.

FES activates the muscles in case of absence of voluntary activity or assists when some voluntary motor control remains. As muscles tire or control decreases, neuromuscular stimulation is intensified to maintain an acceptable level of exercise. Stimulated muscles are the main extensors and flexors: gluteus maximus, vastus medialis, vastus lateralis, rectus femoris, hamstrings, gastrocnemius and ankle dorsiflexors.

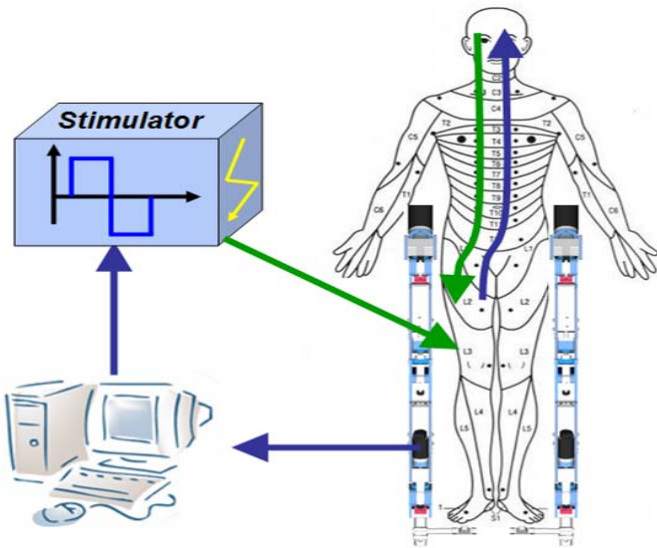

All the results are automatically transmitted to the physician's office to be analysed with our PrescriNet™ software. This e-tool allows complete management of the therapy including inscription of the patient and exercise prescription.

A touch-screen of the MotionMaker™ provides instructions and gives feedback to the patient to inform on his performances, allowing online adaptation of his voluntary participation. **This associates the patient as an actor of his rehabilitation**, thus increases his motivation and self confidence.

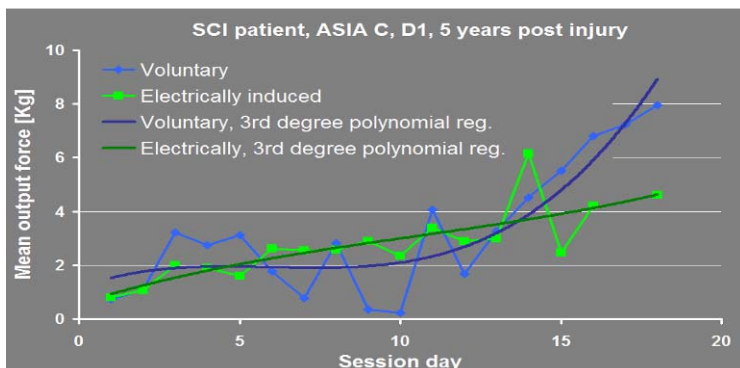

The **benefits** of using the MotionMaker™ have been shown during a clinical study and continue to be proved every day.

- Increase of functional control in the daily tasks
- Increase of electrically induced force
- Improvement of blood circulation
- Increase of voluntary force
- Increase of limb perception
- Decrease of hypertonia and spasticity

MotionMaker™ is accompanied with assisting equipments to optimise the rehabilitation outcomes and the therapist's output.



The patient is resting on the ModuTable™ to achieve preparation of his muscles by stimulation with the StimMaker™.

This device permits warming up and cooling down of the 14 muscles that are intended to be trained on the MotionMaker™.

ModuTable™ helps the therapist to easily transfer the patient onto the MotionMaker™ **in a completely safe manner.**

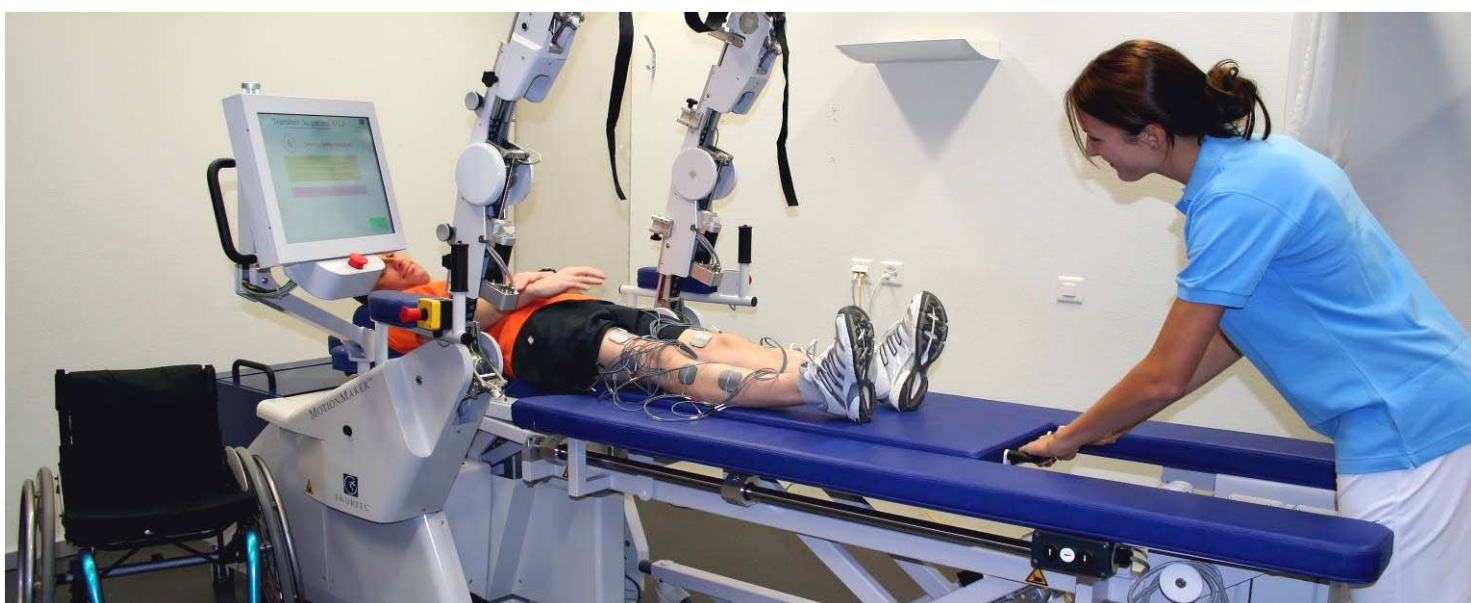

Following **exercises** can be done with the MotionMaker™:

Exercise	Performance
Passive mobilization	Joint mobility and diagnostics
Active mobilization with CLEMS™	Muscle training
Active mobilization with voluntary strength	Motor control training and diagnostics
Active mobilisation with CLEMS™ and voluntary strength	Motor control and muscle training

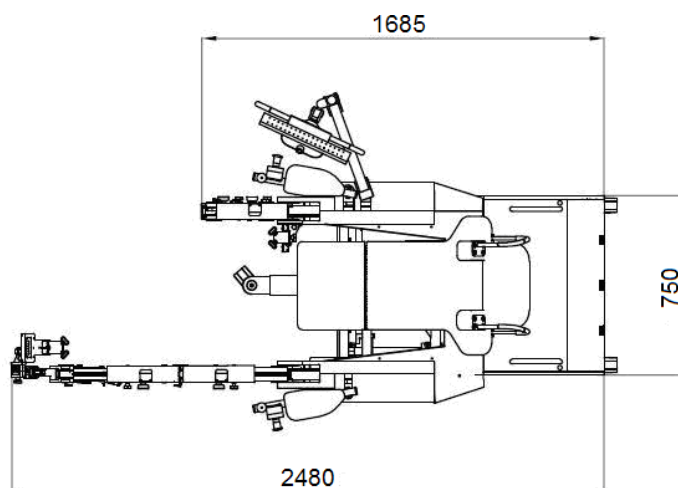
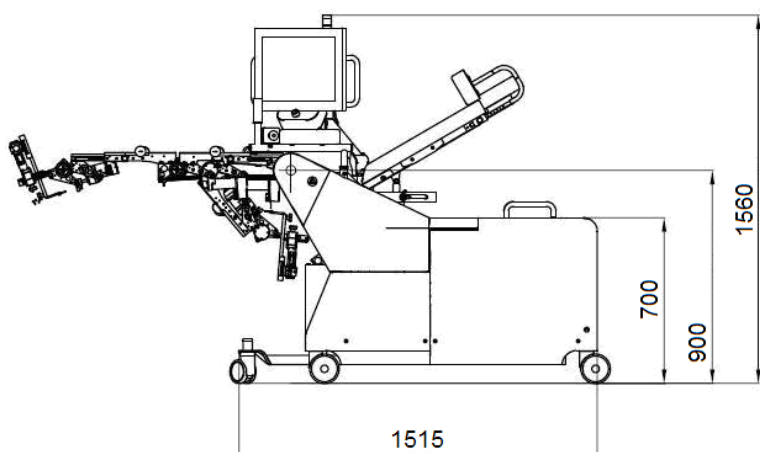

Technical Data

Patient profile	Spinal cord injury, Stroke, Cerebral Palsy, Traumatic brain injury, Multiple sclerosis, Locomotor's infirm
Patient height	~140 to 195 cm
Patient weight	Max. 135 kg
Electrical stimulation	14 channels adjustable from 0 to 150 mA
Stimulation frequency	10-85 Hz
Duration of impulse	100-300 us
Slope of backseat	0° to 80°
Hip range of motion	-15° to 110°
Knee range of motion	-10° to 130°
Ankle range of motion	-45° to 25°

Power supply	230 VAC 50/80 Hz IDA
Layout	152x75x158 cm (LxWxH)
Floor space	4x2 = 8m ² / min room height 2.2m
Weight of device	210 kg
Noise level	Maximum 55 dB[A] – IEC12523
Protective class	IP54
CE Conformity	EEC93 / 42 med. Dev. Directives, appendix II
CE class	Class IIb
Quality Insurance	ISO 13485 – ISO 9001:2008



Monthey, Switzerland

Swortec SA

Les Ilettes
P.O. box 70
1870 Monthey, Switzerland

Tel. : + 41 24 473 40 30
Fax. : + 41 24 473 40 31
<http://www.swortec.com>
info@swortec.ch



SWISS QUALITY

With the compliments of :